

ALUMINUM or POLYCARBONATE

VISOR

Our visors are one piece formed aluminum or polycarbonate secured with 4 stainless steel screws. Choices include: full tunnel or cutaway.

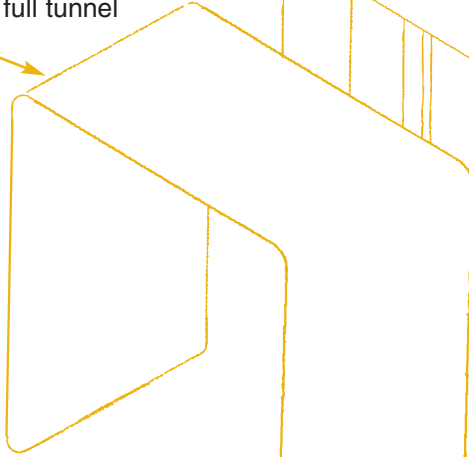

LENS/ GASKET

Your choice of either a glass or polycarbonate lens is secured onto the door using 4 stainless steel screws. This creates a snug seal that is both moisture and dust proof.



DOOR/MOUNTING

Constructed of die cast aluminum alloy #380 or UV stabilized polycarbonate, our doors are designed for minimum weight while providing maximum strength and durability. Easy access to the inside of the housing assured through integrated die cast hinges with stainless steel eyebolts. Stainless steel washers and wing nuts assure positive latching without the use of any special tools.

LAMP SOCKET

Our sockets have a molded body with a 30° serrated base which guarantees proper adjustable positioning of the lamp filament. Bail wire and gasket secures the socket to the reflector, and color coded wires with plug in leads permit installation and removal without the need for specialized tools.

REFLECTOR

ALZAK aluminum reflector with gasket material on flange that excludes dirt and dust from the inner surface to both reflector and lens.

REFLECTOR RING

We use die cast aluminum alloy #380 in our rings, which are mounted in the housing and secured with a captive spring. Hinging and removal of the reflector assembly is easily accomplished without the use of special tools.

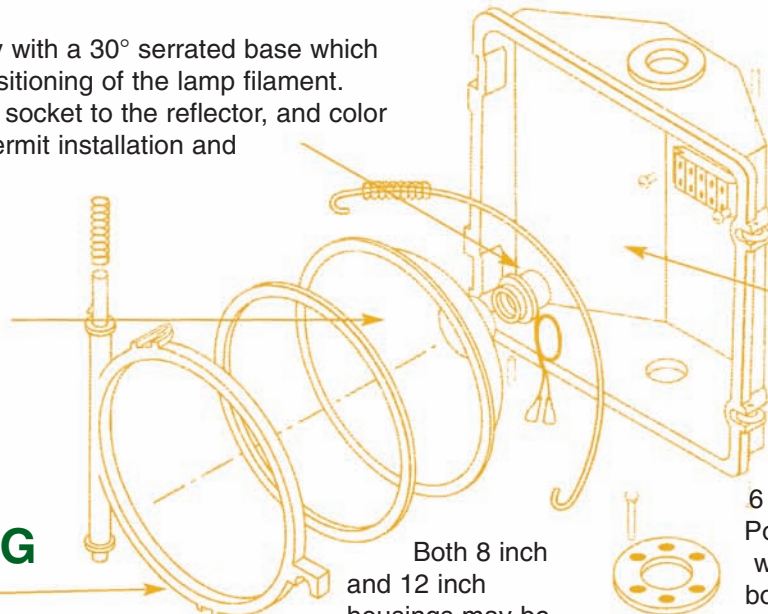

Both 8 inch and 12 inch housings may be fastened together to create multi section or intermixed to create combination signals.

HOUSING

Designed for minimum weight, maximum strength and durability, our housing is constructed of die cast aluminum alloy #380 or UV stabilized polycarbonate. Cast bosses provide precise mounting and wire identification for a 6 position terminal block. Positive self locking ends with a 5 degree serrated boss and provisions for a reflector ring and optional backplates complete the housing.

Pedestrian Signals



800-790-1933 • 703-777-0090 • Fax: 703-771-4040 • Website: Nativeamericanindustriesinc.com

All materials, components and manufacturing processes meet or exceed ITE specifications.

12" section weighs approximately 7 pounds.